

Digestion Systems



en





Digestion systems from Buchi – extensive selection

To determine the nitrogen or protein content in accordance with the Kjeldahl method, it is necessary, in the majority of cases, to digest the related samples using sulfuric acid and a catalyst. Digestion systems utilizing a block heater or an IR heater can be used for this procedure.

The right digestion system for every need

- **Usage in foodstuff, animal feed, environment, pharmaceutical laboratories**

The nitrogen or protein content is an important parameter during the analysis of a wide range of samples. The digestion systems from Buchi can be used universally for every application.

- **Compliance with standard methods using Buchi block digestion systems**

To analyze nitrogen/protein in accordance with officially recognized methods (ex. AOAC, DIN, ISO), block digestion systems are the first choice. In these methods the use of block digestion systems is often recommended.

- **Shortening of the digestion procedure using Buchi IR digestion systems**

Fast pre-heating and cool-down are the key feature of IR digestion systems. For this reason it is possible to significantly shorten the entire digestion process and at the same time increase the sample throughput.

NEW
P.6/7

Block digestion – automation and ease of use

Digestion systems based on a heated aluminum block are widely known and are recommended in many official methods. With many years of experience in this sector, Buchi offers three aluminum block digestion systems. These systems offer varying degrees of automation and ease of use.



Digest System K-437: most convenient digestion system

A complete instrument for the safe digestion of up to 20 samples simultaneously. The samples tubes are evenly heated and all of the acid fumes are collected with the aid of the optional B-414 Scrubber. Digestion temperature and time can be programmed and viewed on the display at all times.

- Undertake standard Kjeldahl digestions on 20 samples in 300 ml sample tubes at the same time
- Simple operation
- Exact temperature during digestion is displayed
- Countdown time indicator is displayed
- All glassware is made of Buchi high quality, borosilicate glass

Digest System K-437

Digest Automat K-438/Digest Automat K-432: highest degree of automation

The models K-438 and K-432 are additionally equipped with an automatic lift for raising and lowering the rack; they also have a feature that allows methods to be programmed and saved. As a result the digestion process is completely automated. Temperature profiles can be entered so that highly foaming or otherwise difficult samples can be digested more easily. If the Digest Automat is connected to a K-370 Distillation Unit, it is possible to initiate the digestion via the K-370, to export methods to a PC and to print them out. The rack holding the samples can be placed directly in the Autosampler K-371.



Digest Automat K-432

- Increased convenience on the digestion of up to 20 samples in 300 ml sample tubes (K-438) or 12 samples in 500 ml sample tubes (K-432)
- Automatic lift for the raising and lowering of the sample rack
- Programmable temperature profile with 4 temperature steps and cool-down
- Data transfer to K-370
- Working memory for 9 programs for different sample matrices
- Built-in clock to start the digestion at a previously defined time

Advantages of Buchi Block digestion:

- Automation reduces time the user needs to be present
- Ease of use makes routine operation easier
- Compliance with official standards (AOAC, DIN, ISO)



Digest Automat K-438

SpeedDigester – flexibility, speed, reproducibility

Using the SpeedDigester IR digestion systems, new standards are set in speed of digestion, flexibility and reproducibility. Using these systems, a wide range of samples can be digested much faster compared to conventional digestion systems. The SpeedDigester K-439 is also the world's first IR digestion system with temperature control, so that exact temperatures can be set.



SpeedDigester K-425

SpeedDigester K-425/K-436: cost-optimized flexibility

On these two systems the heating level is adjusted using continuous controls. The optimized design of the heating chambers reliably ensures all samples are homogeneously heated, an aspect that prevents the foaming of critical samples. The acid fumes produced are removed with the aid of the optional Scrubber B-414. As a consequence the ambient air in the laboratory remains free of harmful vapors.



SpeedDigester K-436

- K-425: 6 x 300 ml or 5 x 500 ml sample tubes
- K-436: 12 x 300 ml or 10 x 500 ml sample tubes
- K-436: two heating chambers that can be controlled individually
- Simultaneous and even boiling of all samples
- Fully sealed suction system for the removal of acid fumes

World innovation SpeedDigester K-439: perfect reproducibility thanks to temperature control

The SpeedDigester K-439 is revolutionizing Kjeldahl digestion. It is the only IR digestion system that has an integrated temperature sensor, so that digestion at exact temperatures is achievable. The advantages of IR and block heating systems are now combined. Using modern application software, digestion methods (temperature ramps and time) can be programmed and saved in the database with a method name. The SpeedDigester K-439 also features an LC display which allows the user to observe the progress during a digestion as a graphical display.



SpeedDigester K-439

- 12 x 300 ml or 10 x 500 ml sample tubes.
- Fast heating and cooling result in significant time savings and as a consequence increased sample throughput.
- Exact temperature control makes it possible to set temperatures; an aspect that contributes to excellent reproducibility.
- 20 pre-defined Buchi digestion methods and 30 individually programmable methods ease routine operation.
- If a scrubber is connected, it is automatically switched on at the start of the digestion and off again at the end of digestion.

Advantages of Buchi IR digestion:

- Time savings due to short heat-up and cool-down times
- Reproducibility thanks to integrated temperature control
- Use of 300 or 500 ml tubes with the same instrument



SpeedDigester K-439 with Scrubber B-414

SpeedDigester – outstanding features

Flexible – SpeedDigester K-425/K-436/K-439



Selection of sample tubes
Tubes with a volume of 300 ml or 500 ml
→ **Optimal sample tube for every application**



Special suction manifolds
Standard: universal use
Condensate trap: aqueous samples
→ **Efficient digestion due to reduced condensation backflow**

H₂O₂-digestion: digestion without catalyst
→ **Fast, environment friendly**



Homogeneous heat distribution
All sample positions are evenly heated
→ **Consistent start of boiling**



Optimal sealing
Special sealing system between sample tube and suction manifold
→ **No unpleasant odors**



Fast heating/cooling
Integrated, powerful IR heater
→ **Enormous time saving**



Unique – SpeedDigester K-439



Easy to use software
Programming of digestion methods
→ **Easy programming**



Clear display
Large LC display with graphic function
→ **Increased ease of use**



Exact temperature control
Sensor ensures temperatures set are maintained
→ **Perfect reproducibility**



Predefined applications
20 Büchi standard methods, 30 individually programmable methods
→ **Simplified routine operation**



Detailed IQ/OQ documentation
Installation qualification and operational qualification
→ **Fast qualification**

Configurations, block digestion systems

All block digestion systems are supplied complete with sample tubes, rack, suction module and hose to the scrubber.

Model	Order no.	Description
Digest Automat K-432	043980	Standard suction manifold, 12 x 500 ml tubes (220–240 VAC, 50/60 Hz)
Digest Automat K-432	043074	Suction manifold with condensate brake, 12 x 500 ml tubes (220–240 VAC, 50/60 Hz)
Digest System K-437	038584	Standard suction manifold, 20 x 300 ml tubes (220–240 VAC, 50/60 Hz)
Digest System K-437	040316	Suction manifold with condensate brake, 20 x 300 ml tubes (220–240 VAC, 50/60 Hz)
Digest Automat K-438	038520	Standard suction manifold, 20 x 300 ml tubes (220–240 VAC, 50/60 Hz)
Digest Automat K-438	040317	Suction manifold with condensate brake, 20 x 300 ml tubes (220–240 VAC, 50/60 Hz)

Configurations, SpeedDigester (IR digestion)

All IR digestion systems are supplied complete with sample tubes, rack, suction module and hose to the scrubber.

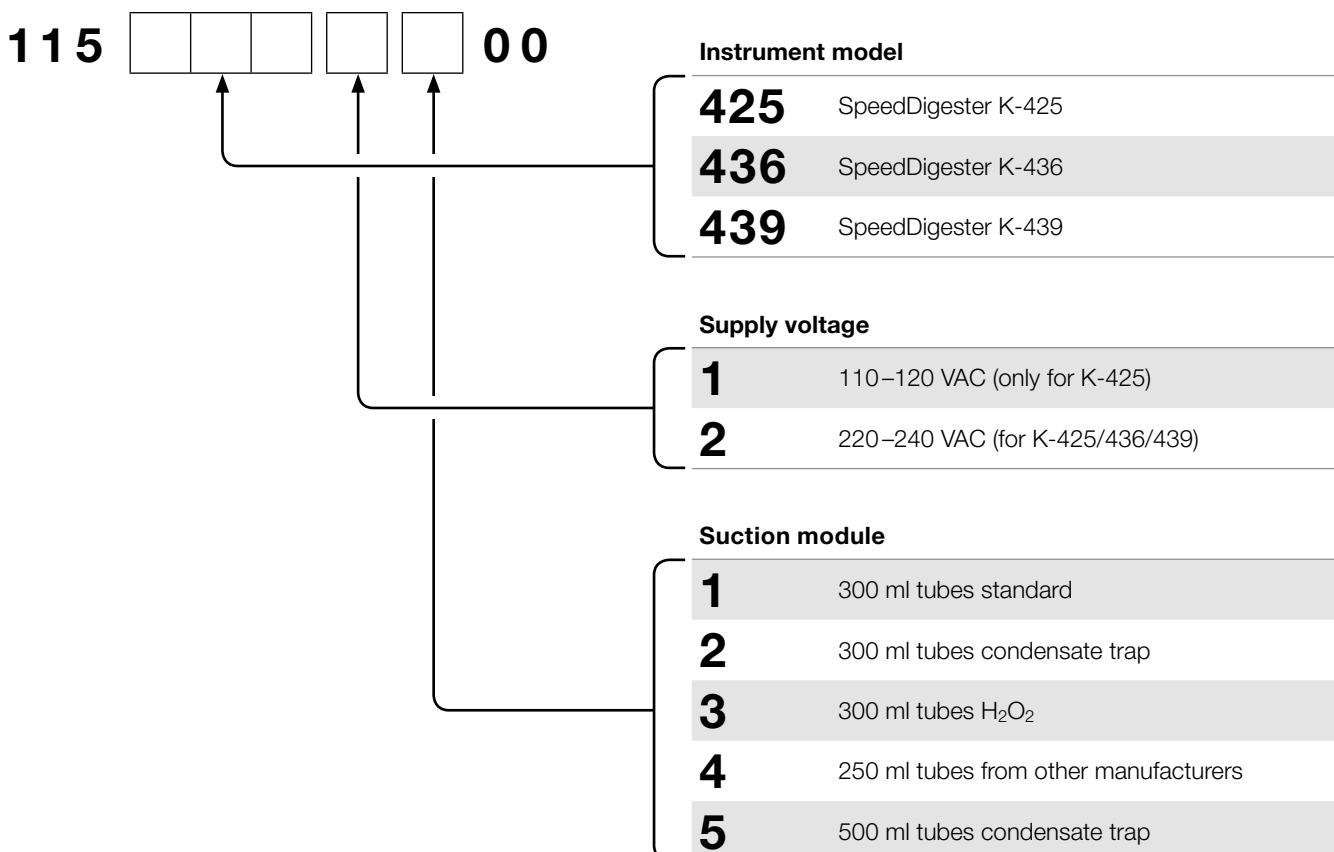

IQ/OQ documentation

There is an increased demand for laboratory instruments to be qualified to ensure that applicable directives or standards (GLP/GMP) are met. The installation qualification and operational qualification play a central role to ensure that a specific measuring accuracy or reproducibility is achieved and documented. Buchi offers complete IQ/OQ packages.



IQ/OQ package for Digest System K-437 and Digest Automat K-432/438

All Buchi block digestion systems have temperature control. The temperature reached is checked using a reference sensor via three holes in the heating block. The complete package for the qualification includes:

- IQ- and OQ dokumentation
- Instrument log book
- IQ sticker and OQ labels
- Various certificates
- Test connector for scrubber interface

NEW



World innovation:

IQ/OQ package for the IR digestion system SpeedDigester K-439

The new SpeedDigester K-439 is the first IR digestion system with temperature control. Temperatures set can be verified using a reference sensor. The qualification package includes:

- IQ- and OQ dokumentation
- Cover for the heating chamber
- IQ sticker and OQ labels
- Instrument log book
- Adapter for positioning the reference sensor
- Test connector for scrubber interface
- Various certificates

Optional accessories

General accessories



Glass caps for occupying empty sample positions, 4 pieces

Order no. 040049



Water jet pump

Order no. 002913



Connection cable to the scrubber for switching on/off via digestion system (not for K-425/436)

Order no. 014738



Kjeldahl tablets, 250 pieces

Order no. 028765



Sample tubes 300 ml, 4 pieces

Order no. 037377



Sample tube 500 ml (SpeedDigester and K-432)

	Order no.
1 piece	026128
4 pieces	043982

Accessories K-432/437/438



Accessories for COD determination in accordance with DIN/ISO methods (K-437/438)

Order no. 043960



Digestion rods to prevent bumping, 10 pieces

Order no. 043087

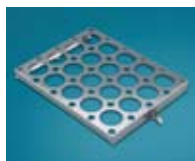

Retainer plate for cleaning tubes in the 20-position rack

Order no. 038559



Holder for 12/20-position rack

Order no. 038639



Drip tray for aluminum block

Order no. 040055



Suction tube with condensate trap

	Order no.
K-437/438	038640
K-432	043072



Cover for 12/20 position rack

Order no. 040052



Additional block for additional insulation (K-437/438)

Order no. 040088



Connection cable K-432/K-438 to K-370 for data transfer

Order no. 043109



IQ/OQ set

	Order no.
K-437	11056166
K-432/438	11055963



Scrubber B-414 with neutralization and adsorption stage

	Order no.
230V, 50Hz	037876
120V, 60Hz	037877



Scrubber B-414 with additional condensation stage

	Order no.
230V, 50Hz	037882
120V, 60Hz	037883

Scrubber (other models on request)

Accessories K-425/436/439



Suction module for H₂O₂ digestion of foaming samples

	Order no.
300 ml	11055853



Suction tube with condensate trap

	Order no.
300 ml	11055865
500 ml	11055851



Holder for 6 sample tubes

	Order no.
300ml	043039



Holder for 12 sample tubes

	Order no.
300ml	043041



Rack for 6 sample tubes

	Order no.
300 ml	11055248



Rack for 5 sample tubes

	Order no.
500 ml	11055327

	Order no.
Base	11055612



IQ/OQ set K-439

Order no. 11056167



Bed-plate for 6-position rack for raising sample tubes

Order no. 11055943



Drip tray for suction manifold

Order no. 11055216



Cover for heating chamber for fast preheating

Order no. 11055842



Insulation cap for unoccupied positions

Order no. 11056024





Insulation plate



	Order no.
300 ml	11055142
500 ml	11055143

Technical data

Block digestion systems

	Digest Automat K-432	Digest System K-437	Digest Automat K-438
Operating voltage	220–240 VAC	220–240 VAC	220–240 VAC
Frequency	50/60 Hz	50/60Hz	50/60Hz
Power consumption	2200 W	2200 W	2200 W
Weight (net)	36 kg	29 kg	36 kg
Dimensions (WxHxD)	435 x 565 (780) x 560 mm	435 x 565 (780) x 535 mm	435 x 565 (780) x 560 mm
Temperature range	50–420 °C (450 °C)	50–420 °C (450 °C)	50–420 °C (450 °C)
Temperature error	± 5 °C > 200 °C ± 2 °C < 200 °C	± 5 °C > 200 °C ± 2 °C < 200 °C	± 5 °C > 200 °C ± 2 °C < 200 °C
Max. number of samples	12 samples (500 ml tubes)	20 samples (300 ml tubes)	20 samples (300 ml tubes)
Approval	CE 	CE 	CE 
IP class	20	20	20

SpeedDigester systems

	SpeedDigester K-425	SpeedDigester K-436	SpeedDigester K-439
Operating voltage	110–120 VAC/220–240 VAC	220–240 VAC	220–240 VAC
Frequency	50/60 Hz	50/60Hz	50/60 Hz
Power consumption	1280 W	2550 W	2000 W
Weight (net)	12 kg	15,5 kg	15,5 kg
Dimensions (WxHxD)	310 x 540 x 620 mm	310 x 540 x 620 mm	310 x 540 x 620 mm
Temperature range	70–580 °C	70–580 °C	50–580 °C
Temperature error	/	/	± 5 K at 200 °C ± 10 K at 550 °C
Max. number of samples	6 samples (300 ml tubes) 5 samples (500 ml tubes)	12 samples (300 ml tubes) 10 samples (500 ml tubes)	12 samples (300 ml tubes) 10 samples (500 ml tubes)
Approval	CE 	CE 	CE 
IP class	20	20	20

BUCHI Labortechnik AG
Postfach
9230 Flawil 1
Schweiz
T +41 71 394 63 63
F +41 71 394 65 65
buchi@buchi.com
www.buchi.com

BUCHI Labortechnik GmbH
Postfach 10 03 51
45003 Essen
Deutschland
Freecall 0800 414 0 414
T +49 201 747 490
F +49 201 237 082
deutschland@buchi.com
www.buechigmbh.de

BUCHI Labortechnik GmbH
Branch Office Netherlands
Postbus 142
3340 AC Hendrik-Ido-Ambacht
The Netherlands
T +31 78 684 94 29
F +31 78 684 94 30
netherlands@buchi.com
www.buchi.nl

BUCHI Italia s.r.l.
Centro Direzionale, Milano Fiori
Pal. A-4, Strada 4
20090 Assago (MI)
Italia
T +39 02 824 50 11
F +39 02 57 51 28 55
italia@buchi.com
www.buchi.it

BUCHI India
Private Ltd.
201, Magnum Opus
Shantinagar Industrial Area
Vakola, Santacruz (East)
Mumbai 400 055,
India
T +91 22 667 18983 / 84 / 85
F +91 22 667 18986
www.buchi.com

BUCHI (Thailand) Ltd.,
77/121, Sin Sathon Tower,
28th FL, Unit C
Krungthornburi Rd.
Klongtong, Klongsan
Bangkok 10600
Thailand
T +66 2 862 08 51
F +66 2 862 08 54
bacc@buchi.com
www.buchi.com

BUCHI Corporation
19 Lukens Drive, Suite 400
New Castle
Delaware 19720
USA
T +1 302 652 3000
F +1 302 652 8777
Toll Free: +1 877 692 8244
us-sales@buchi.com
www.mybuchi.com

BUCHI Hong Kong Ltd.
14th Floor South China Building
1-3 Wyndham Street
Central, Hong Kong
China
T +852 2389 2772
F +852 2389 2774
china@buchi.com
www.buchi.com.cn

BUCHI Shanghai
570 West Huaihai Road
NO.38 Chuangyi Street
200052 Shanghai
China
T +86 21 6280 3366
F +86 21 5230 8821
china@buchi.com
www.buchi.com.cn

BUCHI UK Ltd
5 Whitegate Business Centre
Jardine Way
Chadderton
Oldham OL9 9QL
United Kingdom
T +44 161 633 1000
F +44 161 633 1007
uk@buchi.com
www.buchi.co.uk

BUCHI Sarl
5, rue du Pont des Halles
Z.A. du Delta
94656 Rungis Cedex
France
T +33 1 56 70 62 50
F +33 1 46 86 00 31
france@buchi.com
www.buchi.fr

Nihon BUCHI K.K.
3F IMON Bldg.,
2-7-17 Ikenohata, Taito-ku,
Tokyo 110-0008
Japan
T +81 3 3821 4777
F +81 3 3821 4555
nihon@buchi.com
www.nihon-buchi.jp

We are represented by more than 100 distribution partners worldwide. Find your local representative at

www.buchi.com

Quality in your hands

